



MA-100SP Stereo Tube Condenser Microphone System

The MA-100SP is a matched pair of MA-100 small-diaphragm, vacuum tube condenser microphones with interchangeable cardioid and omnidirectional capsules and a dual power supply. Packaged in a single carrying case, the MA-100SP provides professional recording engineers with a convenient, easy to set up system for stereo recording applications.

From a lineage of successful microphone designs by David Royer, the MA-100SP's cathode follower circuitry provides ample headroom for high SPL applications such as drums and guitar amplifiers. It also excels at the more common applications for small diaphragm, vacuum tube condenser microphones such as acoustic instruments, cymbals, stereo pairs and pianos.

Featuring hand selected, 3-micron cardioid and omni capsules, high quality Jensen audio transformers and military-grade JAN 5840 vacuum tubes, the MA-100SP performs at a level reminiscent of some of the best loved classic small-diaphragm tube condenser microphones. The MA-100SP's power supply can be set for either 110-120 VAC or 220-240 VAC via an external switch. The complete MA-100SP system is burned in for 24 hours, carefully tested and evaluated, then packaged in a protective carrying case.

The Mojave Audio Story

David Royer started Mojave Audio in 1985 in the garage of his house. The location was Fullerton, California, and Mojave Audio was a one-man, custom pro audio gear shop. David is best known for his ribbon microphone designs with Royer Labs, but he originally started out designing and building vacuum tube microphones, mic pre's and compressors for engineers in the Los Angeles area.

Since the mid 1990's, David's custom Mojave products have been used on a number of well-known recordings and have achieved legendary status among a small circle of high-end engineers. With the launching of Mojave Audio, we are able to bring David's non-ribbon designs to the world.

Features:

- Hand-selected interchangeable 3-micron cardioid and omnidirectional capsules
- Jensen audio transformer
- Military grade NOS JAN 5840 vacuum tube
- External switchable power supply voltage
- Ultra clean signal path
- High SPL handling capability

Recommended applications:

- Acoustic Instruments
- Drums
- Guitar Amplifiers
- Piano
- Percussion
- Orchestral Recording
- Choral Recording
- Voice Over and Broadcast
- X/Y, MS, Decca Tree, Blumlein Configurations



MA-100SP

TECHNICAL DATA

Capsules:	Interchangeable Cardioid and Omnidirectional
Diaphragm:	.8" (20.5 mm) diameter
Diaphragm thickness:	3-micron
Frequency Response:	30 Hz - 18 kHz +/- 2.5 dB
Sensitivity:	-39 dB re.1V/pa +/- 1.5 dB
Maximum SPL:	140 dB
Distortion:	Head amp only, not to exceed .4% @ 140 dB SPL
Self Noise:	14 dB nominal, not to exceed 16 dB (A weighted)
Impedance:	450 ohms, transformer balanced (Jensen)
Vacuum Tube:	NOS JAN 5840 pentode wired as triode,
Power Requirements:	100-120 VAC; 220-240 VAC, 50 or 60 Hz. Power consumption approx. 10 watts.

DIMENSIONS AND WEIGHT:

Carrying case with microphone, power supply, shock mount and cables: 9.5 lbs.

Carrying Case: 19" x 12.5" x 5.5"

Microphone: 5.5" x .75", weight 4.5 oz each



Frequency Response and Polar Pattern

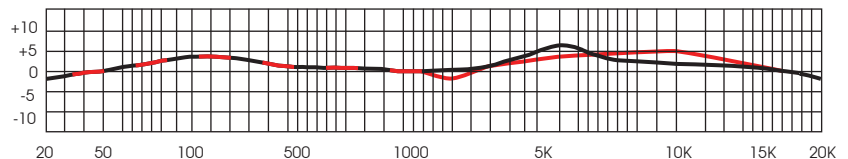
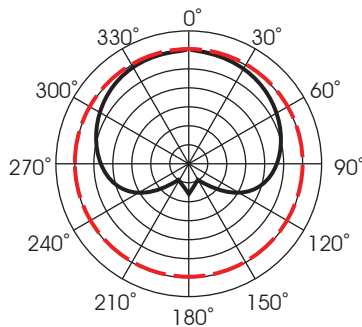

Omni - Red
Cardioid - Black