

MA-100 Vacuum Tube Condenser Microphone

Please visit www.mojaveaudio.com for more information including:

- Recording Tips
- FAQ's
- Customer Service
- Warranty Registration

CONTENTS

INTRODUCTION	2
UNPACKING AND INSPECTION	2
GENERAL INFORMATION	3
SAFETY INSTRUCTIONS	3
OPERATION	4
CARE OF YOUR MICROPHONE	5
TECHNICAL RESPONSE	5
POLAR PATTERN	6
FREQUENCY RESPONSE	7
WARRANTY	7

INTRODUCTION

Congratulations on your purchase of a Mojave Audio MA-100 Vacuum Tube Capacitor Microphone! Your MA-100 was carefully designed and constructed using only the finest materials. The MA-100 microphone is capable of delivering superb performance and, with minimal care, will do so for many years. Your MA-100 was thoroughly tested and given a factory burn-in prior to shipment.

The MA-100's capacitor capsule and electronics are adapted from mid-1950's design practice. By utilizing modern components, the microphone system emulates the performance of the "classic" tube microphones without using esoteric, unreliable, or hard to find parts.

The MA-100 is guaranteed to perform as specified and is suitable for recording even the most demanding music, provided that the microphone is used sensibly.

For optimum performance from your new microphone, please read this manual thoroughly and become familiar with the proper use of the MA-100.

UNPACKING AND INSPECTION

Carefully unpack your MA-100 vacuum tube microphone and verify that all of the components included with the microphone are accounted for. Do not discard any packing materials! If anything is missing or damaged, contact your dealer or Mojave Audio immediately.

Items included with the MA-100 are:

1. MA-100 microphone inside an aluminum style carrying case
2. Interchangeable omnidirectional capsule in case
3. AC operated microphone power supply (verify that the voltage setting, marked on the CE sticker on the bottom of the power supply, is correct for your country)
4. 25-Foot microphone cable with 7-pin male and female connectors
5. MA-100 shock mount and European adapter (fitted to shock mount)
6. AC power cable for power supply - molded IEC business machine type with plug
7. Rugged carrying case for all above items

Verify that the serial number of your MA-100 matches correctly with the one on your receipt. The MA-100 serial number can be found inside the microphone housing. To access, simply unscrew

the bottom ring and slide the body off. When corresponding with Mojave Audio about your microphone or when service is required, we will need to know the serial number, so keep it handy.

GENERAL INFORMATION

The MA-100 is a vacuum tube design and requires a dedicated power supply and seven-pin cable set for operation. These items are provided with the microphone, along with a specially designed shock mount assembly. The capsules are 3-micron, gold-sputtered types, with a interchangeable cardioid and omnidirectional pick-up patterns. The vacuum tube head-amplifier delivers wide bandwidth and low noise operation. The MA-100 utilizes a sub-miniature vacuum tube, which necessitates the need of a dedicated power supply. The vacuum tube is military grade 5840W "new old stock" and will deliver excellent performance for many years. A specially designed, high-quality output transformer delivers an isolated, truly balanced output signal, minimizing the possibility of unwanted noise entering the preamplifier. As with all vacuum tube microphones, a warm-up period is advised for optimum performance; usually about ten minutes.

SAFETY INSTRUCTIONS

WARNING!

To avoid electrical shock to yourself and damage to the MA-100, use proper circuit protection. The MA-100 is normally wired for 115V, 60 Hz operation, however, export models are wired for the voltages of the country to which they are exported to and this information is duly noted on the outside of the box as well as on the bottom of the power supply. The MA-100 uses a line fuse for protection. Never replace this fuse with one of a higher current rating. Use only that type which was supplied with the unit. The power supply cord that is supplied with your MA-100 is a standard "business machine" type and should be examined regularly for defects in the insulation. Never use a cord that has damaged or exposed wires.

There are no user serviceable components inside the MA-100 microphone or its power supply. Always refer service to qualified technician equipped to service this equipment. Never expose the MA-100 microphone, its power supply, or cable set to water or any environment that may create an unsafe electrical hazard. In the event of a malfunction, disconnect the MA-100 immediately and determine the nature of the malfunction before attempting to use it again.

To avoid tripping over the microphone cable, make certain that the cable is not in the way of foot traffic, or suspended in an unsafe manner. Make sure that the microphone stand is secure and not likely to fall.

If you have any questions or concerns about operation of your MA-100 please contact the factory.

OPERATION

When plugging the microphone in, the seven-pin XLR connectors between the microphone and the power supply should be inserted *gently* into their corresponding sockets. Rough handling, misaligned orientation, or trying to force the connections together too quickly could result in bent pins.

Operation Tip!

Your MA-100 was thoroughly checked and burned-in before leaving the factory. We recommend that before using your MA-100 for the first time, you connect the microphone to the power supply and let it warm up for at least thirty minutes. This will drive out any residual moisture that may have collected on the internal components during shipping or storage. Moisture build-up on the capsule or on the other high-impedance components within the microphone can cause random noise or static.

Also note that if the MA-100 is being used with phantom powered microphones in a multiple microphone setup, phantom power may be applied to the channel connected to the MA-100 without ill effect, *provided that your standard 3-pin microphone cables are wired properly.*

A grounded power cord is used to connect the power supply to the electric power line. MA-100 power supplies are shipped pre-wired for standard AC voltage in the country where the microphone is sold. If there is a need to change AC voltage (travel, sale to another country, etc.), an external switch allows the power supply to be configured for 115 or 230 volts. To check which voltage your power supply is set for, see the CE sticker on the bottom of the unit. *(For instructions on changing voltage, with pictures, please visit mojaveaudio.com. We strongly recommend that this work be done by a qualified technician.)*

"Hot plugging" any vacuum tube microphone can damage the mic's electronics, *so always be sure to connect the microphone to the power supply with its multi-conductor cable before turning the power supply on.*

AC LINE FUSE

A spare fuse is included with your MA-100 power supply. It is located in the fuse carrier just above the AC receptacle. To access the fuse, gently pry out the carrier with a flat bladed screwdriver. The fuse is mounted in the clip and the spare is located in a small channel behind the cover. Replace the fuse with the same type as supplied with your microphone.

MAINS VOLTAGE

100 -120 Volts AC

220 Volts AC

FUSE TYPE

T500mAL

T250mAL

In the rare event that you experience fuse failure, identify the cause of the failure before using the microphone again! The most common cause for a fuse to fail would be a damaged

microphone cable or a broken or bent pin on a connector. The next most likely cause for a fuse failure is operation of the power supply on a voltage source incorrect for the supply.

CARE OF YOUR MICROPHONE

Your microphone is a delicate precision instrument and it should be treated as such.

Here are some commonsense rules to keep your microphone healthy.

1. Be careful in your setup so that the microphone and/or power supply never falls to the floor. *Never* suspend the microphone by its cable and be sure to position the cable so that it cannot be tripped over. Drops to the floor have been the demise of many a microphone.
2. NEVER hot-plug the microphone (i.e. plug the microphone into an energized power supply), as the resulting voltage surges can damage the mic's or following preamplifier's electronics.
3. Keep the microphone, cable and power supply in a safe place, such as its carrying case or a microphone locker, when not in use.
4. When plugging in the seven-pin cable between the microphone and power supply, orient the plug correctly and plug the connectors in *gently*. Rough handling or hurry-up plug-ins can result in bent pins.
5. Never connect the power supply to an AC power outlet that has different voltage than what the power supply is set up for.
6. Do not expose the microphone to dusty, smoky or humid environments.
7. Do not attempt repairs unless you are a qualified technician. There are no user serviceable parts in the MA-100.
8. Use a soft, lint free cloth to remove fingerprints and other blemishes on the microphone body. Never use chemicals, solvents or detergents.

TECHNICAL RESPONSE

Capsules:	Interchangeable Cardioid and Omni directional
Diaphragm:	.8" (20.5 mm) diameter
Diaphragm thickness:	3-micron
Frequency Response:	20 Hz - 20 kHz +/- 3 dB
Sensitivity:	-37 dB re.1V/pa +/- 1.5 dB
Maximum SPL:	130 dB
Distortion:	head amp only, not to exceed .4% @ 140 dB SPL
Self Noise:	14 dB nominal, not to exceed 16 dB (A weighted)
Impedance:	450 ohms, transformer balanced (Jensen)
Vacuum Tube:	NOS JAN 5840 pentode wired as triode
Power Requirements:	100-120 VAC; 220-240 VAC, 50 or 60 Hz. Power consumption approx. 10 watts.
DIMENSIONS AND WEIGHT:	Carrying case with microphone, power supply, shock mount and cables: 7 lbs. Carrying Case: 14"x11"x4" Microphone: 5.5"x.75", weight 4.5 oz

POLAR PATTERN

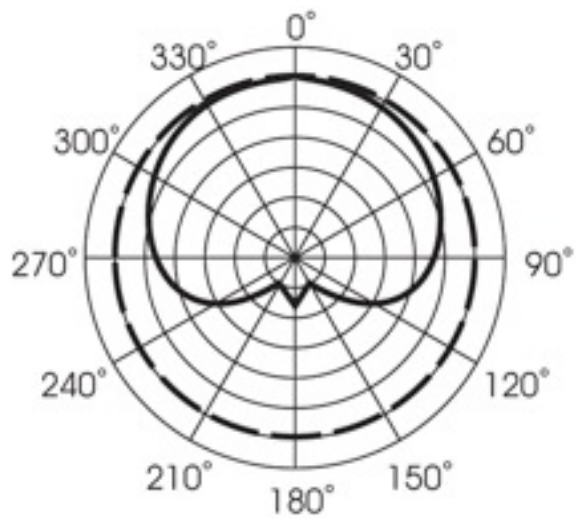

cardioid
omni



FREQUENCY RESPONSE

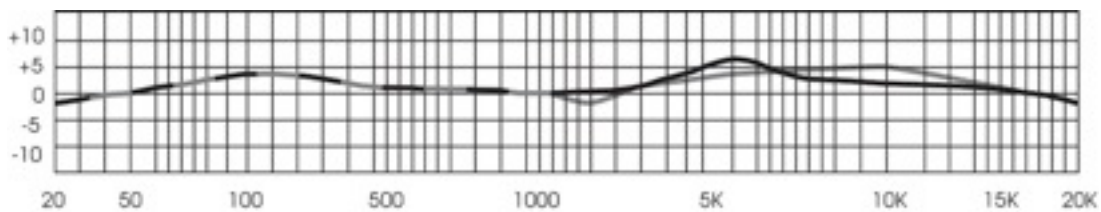

cardioid
omni



WARRANTY

Your Mojave Audio product is warranted to the original owner for a period of two years. Mojave Audio guarantees this product to be free from electrical and mechanical defects and will repair or replace defective components, or replace the microphone at Mojave Audio's option. Should service be required for your Mojave Audio product, please contact the manufacturer. Excellent service will also be provided for products beyond the warranty period at a modest cost for parts and labor.

Please visit mojaveaudio.com for the latest updates and technical information.

MODEL NUMBER _____

SERIAL NUMBER _____

DATE OF PURCHASE _____

PURCHASED FROM _____