



MA-201fet Solid State Condenser Microphone

Please visit www.mojaveaudio.com for more information including:

- Recording Tips
- FAQ's
- Warranty Registration
- Customer Service

CONTENTS

INTRODUCTION	2
UNPACKING AND INSPECTION	2
SAFETY INSTRUCTIONS	3
OPERATION	3
CARE OF YOUR MICROPHONE	3
TECHNICAL SPECIFICATIONS	4
POLAR RESPONSE	5
FREQUENCY RESPONSE	5
WARRANTY	6

INTRODUCTION

Congratulations on your purchase of a Mojave Audio MA-201fet Solid State Capacitor Microphone! Your MA-201fet was carefully designed and constructed using only the finest materials. The MA-201fet microphone is capable of delivering superb performance and, with minimal care, will do so for many years. Your MA-201fet was thoroughly tested and given a factory burn-in prior to shipment.

The MA-201fet is guaranteed to perform as specified and is suitable for recording even the most demanding music, provided that the microphone is used sensibly.

For optimum performance from your new microphone, please read this manual thoroughly and become familiar with the proper use of the MA-201fet.

UNPACKING AND INSPECTION

Carefully unpack your MA-201fet microphone and verify that all of the components included with the microphone are accounted for. Do not discard any packing materials! If anything is missing or damaged, contact your dealer or Mojave Audio immediately.

Items included with the MA-201fet are:

1. MA-201fet microphone inside an aluminum style carrying case
2. MA-201fet shock mount and European adapter (fitted to shock mount)

Verify that the serial number of your MA-201fet matches correctly with the one on your receipt. The MA-201fet serial number can be found inside the microphone housing. To access, simply unscrew the bottom ring and slide the body off. When corresponding with Mojave Audio about your microphone or when service is required, we will need to know the serial number, so keep it handy.

SAFETY INSTRUCTIONS

There are no user serviceable components inside the MA-201fet microphone. Always refer service to qualified technician equipped to service this equipment. Never expose the MA-201fet microphone or cable to water or any environment that may create an unsafe electrical hazard. In the event of a malfunction, disconnect the MA-201fet immediately and determine the nature of the malfunction before attempting to use it again.

To avoid tripping over the microphone cable, make certain that the cable is not in the way of foot traffic, or suspended in an unsafe manner. Make sure that the microphone stand is secure and not likely to fall.

If you have any questions or concerns about operation of your MA-201fet please contact the factory.

OPERATION

When plugging the microphone in, the three-pin XLR connectors between the microphone and the mic preamp should be inserted *gently* into their corresponding sockets. Rough handling, misaligned orientation, or trying to force the connections together too quickly could result in bent pins.

The MA-201fet requires standard 48v phantom to operate.

CARE OF YOUR MICROPHONE

Your microphone is a delicate precision instrument and it should be treated as such.

Here are some commonsense rules to keep your microphone healthy.

1. Be careful in your setup so that the microphone never falls to the floor. *Never* suspend the microphone by its cable and be sure to position the cable so that it cannot be tripped over. Drops to the floor have been the demise of many a microphone.
2. Never hot-plug the microphone (i.e. plug the microphone into a mic pre with 48v phantom power turned on), as the resulting voltage surges can damage the mic's or following preamplifier's electronics. Always connect mic first, then turn on 48v supply.
3. Keep the microphone in a safe place, such as its carrying case or a microphone locker, when not in use.

4. When plugging in the three-pin XLR cable between the microphone and mic preamp, orient the plug correctly and plug the connectors in *gently*. Rough handling or hurry-up plug-ins can result in bent pins.
5. Do not expose the microphone to dusty, smoky or humid environments.
6. Do not attempt repairs unless you are a qualified technician. There are no user serviceable parts in the MA-201fet.
7. Use a soft, lint free cloth to remove fingerprints and other blemishes on the microphone body. Never use chemicals, solvents or detergents.

TECHNICAL SPECIFICATIONS

TRANSDUCER TYPE:	Externally polarized pressure gradient capacitor
DIAPHRAGM:	1-inch diameter, gold sputtered, single-sided
DIAPHRAGM THICKNESS:	3-micron
POLAR PATTERN:	Cardioid
FREQUENCY RESPONSE:	20 Hz-20kHz, + 3dB
SENSITIVITY:	-39 dB re. 1V/pa
MAXIMUM SPL:	125 dB
DISTORTION:	<1% @120dB SPL, <3% @ 134dB SPL
SELF NOISE:	14dB nominal, not to exceed 16dB (A weighted)
IMPEDANCE:	550 ohms, transformer balanced (Jensen)
POWERING:	48VDC phantom power; current .68mA.
DIMENSIONS AND WEIGHT:	Carrying case with microphone, shock mount: 10" x 9" x 4.5", 4 lbs. Microphone: 7 5/8" x 2", 1 lb.

POLAR RESPONSE

Type: Cardioid

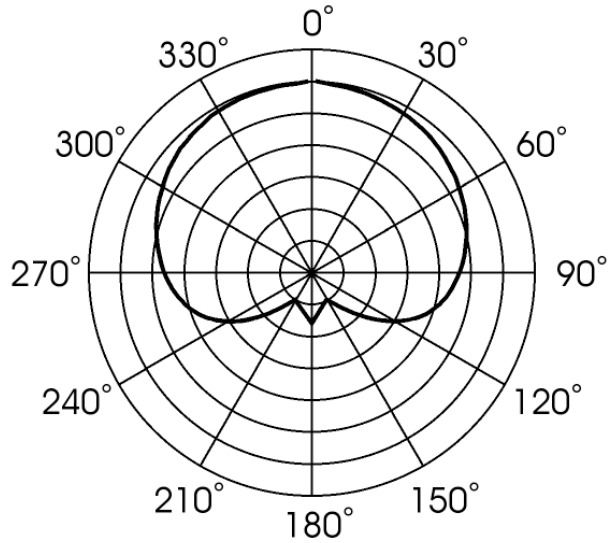

FREQUENCY RESPONSE

20Hz – 20kHz, ± 2.5 dB

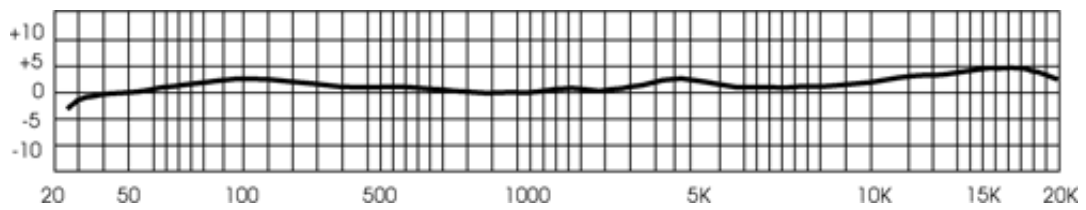

WARRANTY

Your Mojave Audio product is warranted to the original owner for a period of two years. Mojave Audio guarantees this product to be free from electrical and mechanical defects and will repair or replace defective components, or replace the microphone at Mojave Audio's option. Should service be required for your Mojave Audio product, please contact the manufacturer. Excellent service will also be provided for products beyond the warranty period at a modest cost for parts and labor.

Please visit mojaveaudio.com for the latest updates and technical information.

MODEL NUMBER_____

SERIAL NUMBER_____

DATE OF PURCHASE_____

PURCHASED FROM_____